

УЧЕТНИЙ ЛИСТ
IS-TPSC

A.110

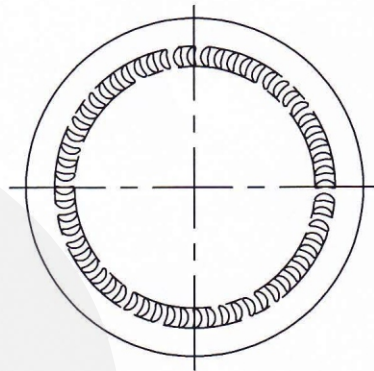
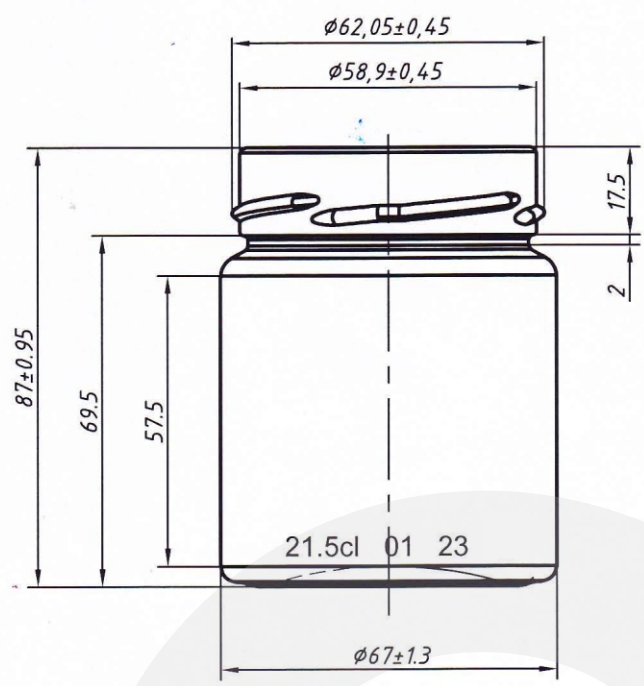

Bottom view

The controllable sizes of the glass finish:
 $\phi 62,05 \pm 0,45$
 $\phi 58,9 \pm 0,45$

Finish type III-63 (deep)

CENTERGLASSLINE

The signature and date	<p>Characteristics Full capacity, cm^3 -215±6 Weight recommended, g -170</p>		<p>The packing scheme of the jars in the pallet</p>							
Instead of accession N Duplicate accession N	<p>SF-37780441-003:2010; GOST 5717.1 Thickness of walls not less, mm-1,4 ,at application of hardening-1,2 Thickness of a bottom not less, mm-2,0 Thermal stability ,difference of temperatures, not less, °C -40 Internal hydrostatic pressure during 5s not less, kgf/cm^2 -3 Resistance to effort of compression not less, N-2200</p>									
The signature and date	<p>Maximum deviations on height, mm ±0.95 on diameter, mm ±1.3 Concavity of an end face of a nimbus mouth no more, mm 0,3 Other dimensions are for manufacturing of mold sets</p>		<p>Quantity of layers: 15 Quantity of jars in the pallet: 4335 Weight of the pallet, kg: 801 Roof: a cardboard Cover: thermocontractable</p>							
Original accession N	<p>Agreed:</p>		<p>A.110</p>							
	<p>Chang. Letter</p>	<p>Document N</p>	<p>Signature</p>	<p>Date</p>						
	<p>Designed</p>	<p>Cosovschi P.</p>	<p>[Signature]</p>	<p>22.01.24</p>						
	<p>Const.-r principal</p>	<p>Cosovschi P.</p>	<p>[Signature]</p>	<p>22.01.24</p>						
	<p>Dir. of manuf.</p>	<p>Balfajji L.</p>	<p>[Signature]</p>	<p></p>						
<p>Jar III-63-215 "Pomodoro deep"</p>			<table border="1"> <thead> <tr> <th>Letter</th> <th>Weight</th> <th>Scale</th> </tr> </thead> <tbody> <tr> <td></td> <td></td> <td>1:1</td> </tr> </tbody> </table>	Letter	Weight	Scale			1:1	
Letter	Weight	Scale								
		1:1								
<p>Glass colourless</p>			<table border="1"> <thead> <tr> <th>Sheet</th> <th>Sheets</th> <th>1</th> </tr> </thead> <tbody> <tr> <td></td> <td></td> <td></td> </tr> </tbody> </table>	Sheet	Sheets	1				
Sheet	Sheets	1								